

HOTLINE

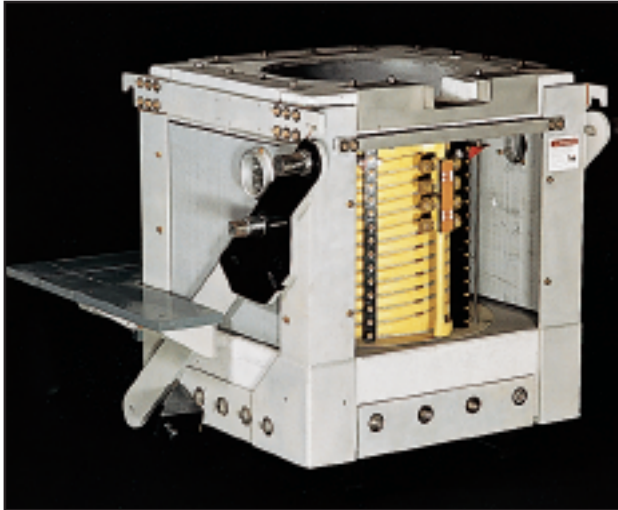

EMSCO Box Furnace Rebuilds



Improvement and development of specialty castables improve box furnace life and reduce repair costs

The box furnace ranging in size from 50 to 3000 pounds has maintained its popularity with foundrymen for more than 35 years. Both ferrous and non-ferrous shops have chosen it because of its simplicity, low cost and accessibility to the coil for inspection and maintenance.

EMSCO has breathed new life into the box furnace. With its strong and durable EMSCAST top and bottom, an **EMSCO** rebuilt box furnace has eliminated two areas of costly maintenance in the past. Both top and bottom are reinforced with heavy stainless steel threaded rod for extra durability.

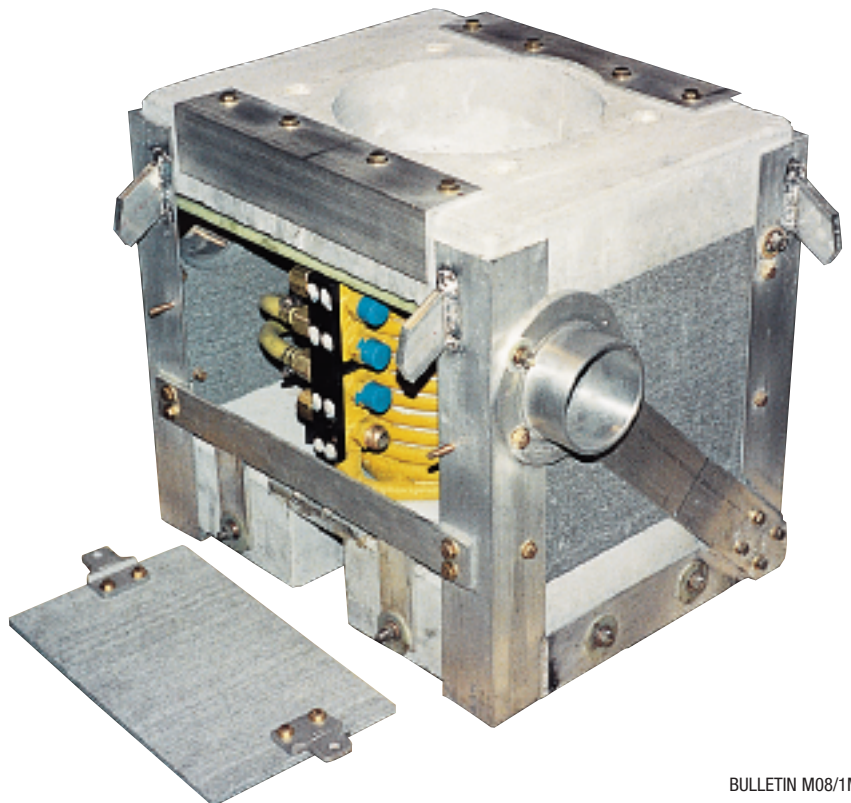
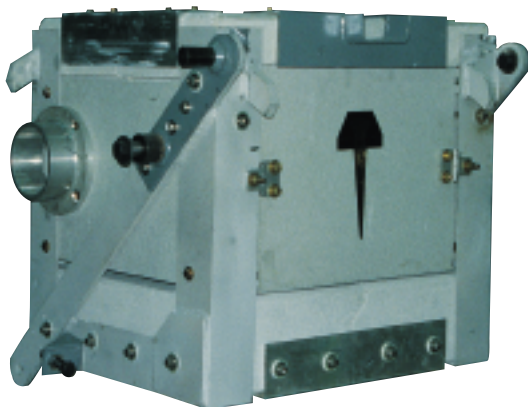
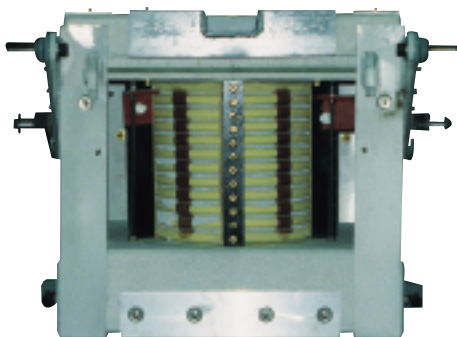

BULLETIN M08/1M/0408

NATIONWIDE TOLL-FREE NUMBERS
Repair Centers - 877.77.EMSCO (773.6726) | Installations - 800.858.7030

www.emsco.com

They are stress-jointed precast to absorb expansion forces and have all tie rod holes precast for user convenience. Oven curing at elevated temperatures drives off any chemically bonded moisture; thereby preventing premature cracking in the field as the furnace is used.

In the past, it was time and labor intensive to do in-house replacement of a furnace bottom. That is not the case with an EMSCAST bottom. When the first EMSCAST bottom is placed into a furnace, simple modifications are made to the furnace frame. These modifications make for ease in removal and replacement of the bottoms should this ever be necessary. All replacement parts from nuts and bolts to panels, tops and bottoms are stocked. This assures a fast turnaround whatever the need.

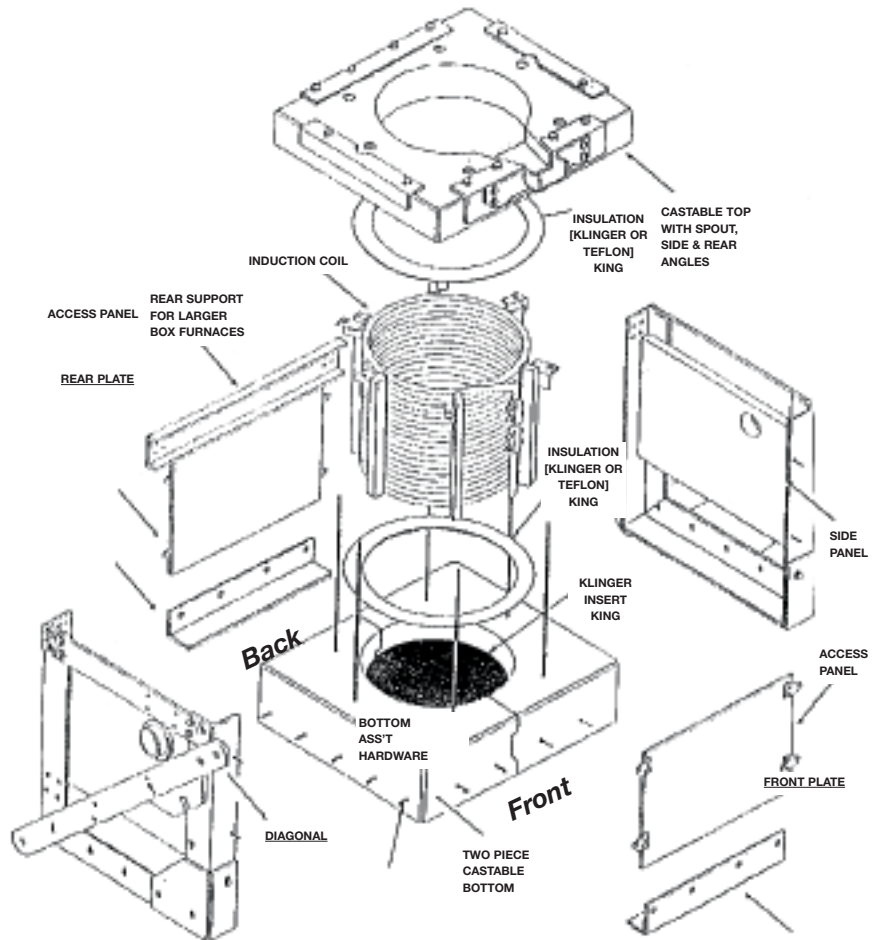

EMSCO is ready when you need us...every day.

EMSCO's Commitment to you

KNOWLEDGE: EMSCO will begin each project with a customer-focused understanding of the problem to be solved and a soundly engineered approach to the solution.

COST: EMSCO will, when possible, offer more than one level of service and will explain the costs and compromises associated with each. Every option we propose will meet industry standards for safety.

QUALITY: EMSCO will understand and meet the quality expectations agreed to at the start of the project. Warranties will be explained and will set the standard for the industry.

OUR GOAL: EMSCO will provide quality services at reasonable prices so that our customers have the competitive edge in their markets.

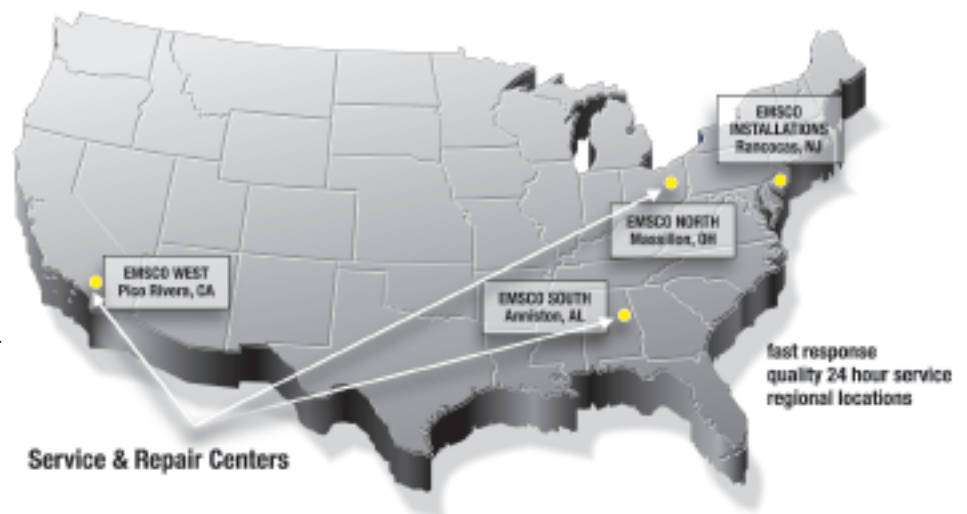

NATIONWIDE TOLL-FREE NUMBERS

Repair Centers - 877.77.EMSCO (773.6726) | Installations - 800.858.7030

www.emsco.com